



HEIDENHAIN



ND 287

Centering
with Two Scanning Heads

1 Centering of graduation carriers with two scanning heads

Centering with two scanning heads is considered to be the most accurate centering method for the graduation carriers (circular scale or scale drum) of modular angle encoders. With this centering method, the angle position is directly used for centering; there is no need for any mechanical or optical auxiliary geometry.

You can use this centering method with all HEIDENHAIN modular angle encoders with 1 V_{PP} or EnDat interface.



For more information, you can download an instructional video from the download area at www.heidenhain.de.

2 Aids and requirements

The following aids are needed for centering with two scanning heads:

- Two scanning heads of the same design with the corresponding adapter cables (one scanning head is needed only for the centering process)
- ND 287 evaluation unit
- Encoder module for the ND 287 evaluation unit for connection of an additional HEIDENHAIN encoder to the X2 axis
- Current product software



The current version of the product software is available at www.heidenhain.de under Software > Filebase > Evaluation Electronics > ND 287 > Software

The following additional requirements must be fulfilled:

- Mounting option (threaded hole and installation space) for the second scanning head directly opposite (180°)
- Accessibility for removal of the second scanning head after centering

3 Preparing the graduation carrier of the angle encoder

To perform centering, you have to roughly align the graduation carrier (circular scale or scale drum) and mount the second scanning head.

- ▶ Mount the graduation carrier according to the mounting instructions
- ▶ Pre-center the graduation carrier mechanically or optically to a radial runout of less than approx. 50 µm
- ▶ Mount the scanning heads approximately directly opposite ($180^\circ \pm 5^\circ$) from each other and align them as follows:
 - Rough alignment using a spacer shim or mounting aid
 - No fine adjustment necessary (signal amplitudes of approx. 0.7 V_{PP} are sufficient)
 - No adjustment of the reference mark signals required
- ▶ Connect the scanning heads by means of the adapter cables to the encoder inputs X1 and X2 of the ND 287 evaluation unit

4 Preparing the evaluation electronics (1 V_{PP} interface)

To perform centering, you have to configure the settings for the scanning heads and the screen display on the ND 287 evaluation unit.



Product software V1.09 is required for centering via the 1 V_{PP} interface.

- ▶ Switch on the product
- ▶ Press the **C** key
- ▶ Press the **SETUP ▶ INSTALLATION SETUP** soft key
- ▶ Enter the code number **95148**, if required.
- ▶ Make the following settings in the submenus:
 - In **COUNTER SETTINGS**, select the **2 AXES** mode by pressing the **1 AXIS / 2 AXES** soft key
 - In **ENCODER SETUP ▶ INPUT X1 ▶ ENCODER TYPE**, select **LINEAR** by pressing the **TYPE** soft key
 - The **ENCODER SETUP (X1)** form allows you to define the following settings:
 - In the **SIGNAL PERIOD** field, press the **COARSER** or **FINER** soft keys to select the corresponding value for the encoder (see "Signal period settings", Page 6)
 - In the **REFERENCE MARK** field, select **NONE** by pressing the **REF MARK** soft key
 - In the **COUNT DIRECTION** field, select the **POSITIVE** mode by pressing the **POSITIVE/ NEGATIVE** soft key
 - Repeat the encoder settings for **INPUT X2**
 - In **DISPLAY CONFIGURATION ▶ INPUT X1 ▶ DISPL. RESOLUTION**, set the display resolution to **0.0005** by pressing the **COARSER** or **FINER** soft keys
 - Repeat the display settings for **INPUT X2**
 - In **COUNTER SETTINGS**, open the **FORMULA FOR FUNCTION f(X1,X2)** form by pressing the **FUNCTION f(X1,X2)** soft key
 - Enter the formula $f(X1,X2)=(X1-X2)/2$ in the **FORMULA FOR FUNCTION f(X1,X2)** form and confirm with the ENTER key
 - In **ERROR COMPENSATION ▶ INPUT X1**, select the **OFF** mode by pressing the **ERROR COMP.** soft key
 - Repeat the error compensation settings for **INPUT X2**
- ▶ Press the **SETUP ▶ JOB SETUP** soft key
- ▶ Make the following settings in the submenus:
 - In **UNIT OF MEASURE**, select **mm** by pressing the **mm/inch** soft key
 - In **SCALING FACTOR**, select **OFF** by pressing the **ON/OFF** soft key
- ▶ Use the NAVIGATION key to switch to soft-key level 3
- ▶ Press and hold the **X1** soft key until the display value **f(X1,X2)** is shown
- > The evaluation unit's display shows the radial runout of the graduation carrier in μm
- > The algebraic sign shows the direction of the radial runout

Settings for the 1 V_{pp} interface**Press the SETUP ► INSTALLATION SETUP soft key**

COUNTER SETTINGS	APPLICATION	2 AXES			
		FUNCTION f(X1,X2)		f(X1,X2)= (X1-X2)/2	
ENCODER SETUP	INPUT X1 INPUT X2	ENCODER TYPE	LINEAR	SIGNAL PERIOD	see "Signal period settings", Page 6
				REFERENCE MARK	NONE
				COUNTING DIRECTION	POSITIVE
DISPLAY CONFIGURATION	INPUT X1 INPUT X2	DISPLAY RESOLUTION	0.0005		
ERROR COMPENSATION	INPUT X1 INPUT X2	OFF			

SETUP ► JOB SETUP soft key

UNIT OF MEASURE	LINEAR	mm
SCALING FACTOR	INPUT X1 INPUT X2	OFF

Signal period settings

Encoder	Signal period (µm)
ERP 4000/ERP 8000	1
ERP 1000	7.3
ERA 4200/ERO 2000	20
ERA 4400	40
ERA 4800	80
ERO 6000	25
ERO 6100	50
ERM 2200	200
ERM 200/ERM 2400	400
ERM 2900	1000

5 Preparing the evaluation electronics (EnDat interface)

To perform centering, you have to configure the settings for the scanning heads and the screen display on the ND 287 evaluation unit.



Product software V0.36 (special version) is required for centering via the EnDat interface.

- ▶ Switch on the product
- ▶ Press the **C** key
- ▶ Press the **SETUP ▶ INSTALLATION SETUP** soft key
- ▶ Enter the code number **95148**, if required
- ▶ Make the following settings in the submenus:
 - In **COUNTER SETTINGS**, select the **2 AXES** mode by pressing the **1 AXIS / 2 AXES** soft key
 - In **DISPLAY CONFIGURATION ▶ INPUT X1 ▶ DISPL. RESOLUTION**, set the display resolution to **0.0001** by pressing the **COARSER** or **FINER** soft keys
 - In **DISPLAY CONFIGURATION ▶ INPUT X1 ▶ ANGLE DISPLAY**, set the value to **+/-180°**
 - Repeat the display settings for **INPUT X2**
 - In **ERROR COMPENSATION ▶ INPUT X1**, select the **OFF** mode by pressing the **ERROR COMP.** soft key
 - Repeat the error compensation settings for **INPUT X2**
- ▶ Press the **SETUP ▶ JOB SETUP** soft key
- ▶ Make the following settings in the submenus:
 - In **UNIT OF MEASURE ▶ ANGLE**, select the value **RADIAN MEASURE** by pressing the **ANGLE** soft key
 - In **SCALING FACTOR ▶ INPUT X1**, enter the value calculated by means of the formula **SCALING FACTOR = 4 / drum diameter [mm]** using the keyboard
Example: Outside diameter of scale drum 127 mm →
scaling factor = 4 / 127 = 0.031
 - Repeat the scaling factor settings for **INPUT X2**
- ▶ Use the NAVIGATION key to switch to soft-key level 3
- ▶ Press and hold the **X1** soft key until the display value **X1 - X2** is shown
- ▶ Use the NAVIGATION key to switch to soft-key level 2
- ▶ Check whether the values are displayed in **rad** and change them, if necessary
- > The evaluation unit's display shows the radial runout of the graduation carrier in mm
- > The algebraic sign shows the direction of the radial runout

Settings for the EnDat interface**Press the SETUP ► INSTALLATION SETUP soft key**

COUNTER SETTINGS	APPLICATION	2 AXES	
DISPLAY CONFIGURATION	INPUT X1	DISPLAY RESOLUTION	0.0001
	INPUT X2	ANGLE DISPLAY	+/- 180°
ERROR COMPENSATION	INPUT X1	OFF	
	INPUT X2		

SETUP ► JOB SETUP soft key

UNIT OF MEASURE	ANGLE	RADIAN MEASURE
SCALING FACTOR	INPUT X1	4 / drum diameter [mm]
	INPUT X2	

6 Performing centering

Centering of the graduation carrier (circular scale or scale drum) is performed iteratively in multiple runs and becomes more accurate with every repetition.

- ▶ Check the torque of the mounting screws on the graduation carrier. All screws must be tightened with the same torque
- ▶ Press **C** to set the position display unit to zero
- ▶ Performing centering:
 - Rotate the graduation carrier by at least one rotation and define the minimum position value
 - Keep the graduation carrier in this position and press **C** to set the position display to zero
 - Rotate the graduation carrier by at least one rotation and find the maximum position value
 - Keep the graduation carrier in this position and remember the position value
 - By tapping lightly perpendicularly to the scanning heads, move the graduation carrier halfway to the position value displayed before

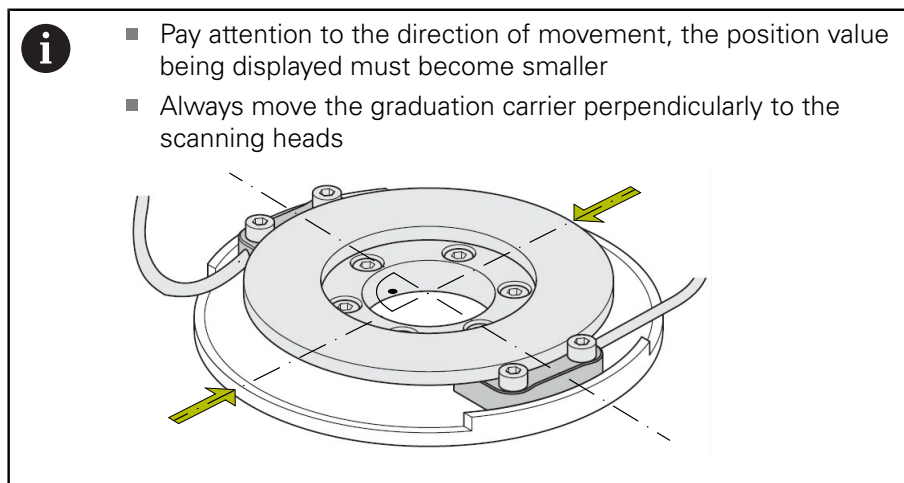

- ▶ Repeat the centering process until the desired centering accuracy has been reached
- > Centering is completed
- ▶ Finish mounting of the graduation carrier according to the mounting instructions
- ▶ Verify the centering accuracy again after mounting
- ▶ Remove the second scanning head again
- ▶ Adjust and mount the other scanning head in its final position according to the mounting instructions

HEIDENHAIN

DR. JOHANNES HEIDENHAIN GmbH

Dr.-Johannes-Heidenhain-Straße 5

83301 Traunreut, Germany

☎ +49 8669 31-0

FAX +49 8669 32-5061

E-mail: info@heidenhain.de

Technical support FAX +49 8669 32-1000

Measuring systems ☎ +49 8669 31-3104

E-mail: service.ms-support@heidenhain.de

NC support ☎ +49 8669 31-3101

E-mail: service.nc-support@heidenhain.de

NC programming ☎ +49 8669 31-3103

E-mail: service.nc-pgm@heidenhain.de

PLC programming ☎ +49 8669 31-3102

E-mail: service.plc@heidenhain.de

APP programming ☎ +49 8669 31-3106

E-mail: service.app@heidenhain.de

www.heidenhain.de

